

Qualcomm C-V2X: IPv6 Solution Options

Application Note

80-PE732-96 Rev. AB

March 16, 2022

All Qualcomm products mentioned herein are products of Qualcomm Technologies, Inc. and/or its subsidiaries.

Qualcomm is a trademark or registered trademark of Qualcomm Incorporated. Other product and brand names may be trademarks or registered trademarks of their respective owners.

This technical data may be subject to U.S. and international export, re-export, or transfer (“export”) laws. Diversion contrary to U.S. and international law is strictly prohibited.

Qualcomm Technologies, Inc.
5775 Morehouse Drive
San Diego, CA 92121
U.S.A.

Revision history

Revision	Date	Description
AA	March 2022	Initial release
AB	March 2022	Updated chapters 1 and 4

Contents

1	Overview of C-V2X IPv6 transactions.....	6
1.1	Conventions.....	8
2	C-V2X TCP test application.....	9
2.1	Command list and options of cv2x_tcp_test tool.....	10
2.2	Connection management due to link-local address change	11
2.3	Add link-local accommodations to ITS products for Internet application.....	11
2.4	Implement OBU and RSU product ITS stacks	12
2.4.1	ITS application implementation on onboard unit.....	12
2.4.2	ITS application implementation on roadside unit.....	13
3	Reference test configuration	15
3.1	Run link-local adaptation of OBU/RSU cv2x_tcp_test.....	16
4	Feature support and availability	18
A	References	19
A.1	Reference documents and websites.....	19
A.2	Acronyms and terms	19

Figures

- Figure 1-1 OBU communication with SCMS server via RSU..... 7
- Figure 2-1 Reference test configuration 9
- Figure 3-1 OBU and RSU connection to SCMS server 15
- Figure 3-2 C-V2X packet transmission between OBU-RSU-SCMS server..... 17

Tables

Table 1-1 Global IPv6 and link-local IPv6 support.....	7
Table 2-1 Reference application: Command list and options.....	10
Table 2-2 Command examples.....	10
Table 2-3 Implement IP connection on an OBU using global IPv6 or link-local.....	12
Table 2-4 Implement IP connection on a RSU using global IPv6 or link-local.....	13
Table 4-1 Global IPv6 and link-local IPv6 support.....	18
Table A-1 Reference documents and websites.....	19
Table A-2 Acronyms and terms.....	19

1 Overview of C-V2X IPv6 transactions

While most of the latest Qualcomm® C-V2X chips support wireless sidelink global IPv6 traffic concurrent with other non-IP V2V safety messages, there may still be few early V2X ITS devices that only support link-local IP addresses. Where IEEE 1609.3 is used, sidelink Transmission Control Protocol (TCP) IPv6 connections can be useful for brief data transfer sessions between vehicles and networked application servers that are connected via roadside units (RSUs). Example use cases include:

- The use cases defined by the following SAE application standards:
 - J2945/3: Requirements for Road Weather Applications
 - J2945/C: Traffic Probe Use and Operations
- Security Credential Management System (SCMS) exchanges

Most C-V2X vehicle onboard units (OBUs) may choose to implement non-real time V2I functions over traditional unicast links like WWAN or Wi-Fi. Nevertheless, with RSU-enabled locations, some OBUs may occasionally transact over LTE-V2X sidelink instead. Such IP sidelink sessions are possible even when the equipment only supports link-local addressing.

Global IPv6 addressing is fully supported by C-V2X IEEE 1609.3 radio profile. Newer Qualcomm® Modem software and Telematics SDK features provide all the APIs required for both OBU and RSU implementations of such IPv6 global sessions.

A 'Reference ITS Stack,' as part of the Telematics SDK, demonstrates how to build a WAVE Router Advertisement (WRA) on the RSU and how the OBU can enable generic IPv6 Internet access through the RSU. Nevertheless, system integrators may encounter an OBU/RSU product that supports only link-local addressing on the C-V2X radio interfaces. Adding OBU/RSU support for TCP sessions with link-local limited devices is straightforward. However, apart from updating the device to support IPv6 global addressing, few additional software configuration steps must be performed.

Device developers can find detailed technical documentation and open-source samples on how to implement on the Qualcomm Developer Network website. These techniques allow ITS OBU TCP applications to connect to application servers through an RSU. See Chapter 4 for feature support on Qualcomm products.

The following figure shows an overview of how the OBU communicates with SCMS server via RSU.

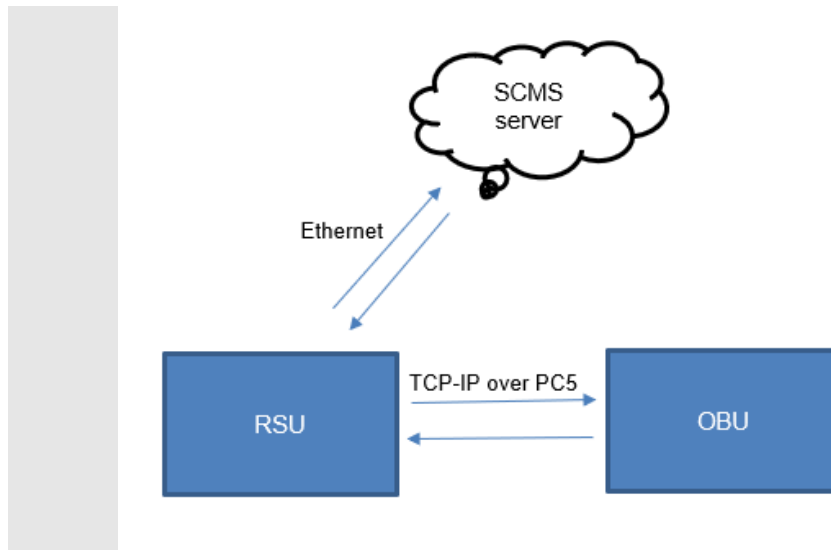

Figure 1-1 OBU communication with SCMS server via RSU

Regardless of the IPv6 address scope (link-local or global), these TCP sessions are first considered by the OBU's ITS stack upon the reception of IEEE 1609.3 WAVE Service Advertisements (WSA), which includes a WRA. The WRA allows OBUs to discover the RSU's IP configurations as they come into wireless range. When supported by OBU and RSU, global addressing allows OBUs to receive a single WRA, then configure their own IPv6 addresses and reach an application server. It is similar to the SSID beacon of a Wi-Fi access point, but it is combined with the DHCP server and secured with an IEEE 1609.2 signature. Additionally, it only requires a single broadcast message. Link-local limitations can be overcome by ensuring RSUs are preconfigured with simple proxies that are advertised with specific PSIDs to reach specific servers.

To enable these link-local accommodations on RSUs, each supported Internet destination server needs a dedicated PSID that is included in the service list of the WSA. This WSA broadcasts the availability of these link-local proxies to passing OBUs. The RSU's V2X-IP interface address and listening ports are included in these WRAs. The OBU establishes a wireless connection to the RSUs link-local address and port, using the information from the WRA. The RSU opens new connections to the known application server associated with that listening port/PSID, and bidirectionally relays the TCP data between the OBU and Internet application server. SSL traffic should be tunneled between client and server to maintain end to end security. The code that demonstrates this is available in the open-source `cv2x_tcp_test` sample application.

The following table captures the availability of IP addressing mechanisms in Qualcomm products for C-V2X.

Table 1-1 Global IPv6 and link-local IPv6 support

Chip product	Global IPv6	Link-local IPv6
MDM9150	May 2022	Yes
SA515M	Yes	Yes

1.1 Conventions

Function declarations, function names, type declarations, attributes, and code samples appear in a different font, for example, `cp armcc armcpp`.

Code variables appear in angle brackets, for example, `<number>`. Commands to be entered appear in a different font, for example, `copy a:*.* b:.`

Button and key names appear in bold font, for example, click **Save** or press **Enter**.

2 C-V2X TCP test application

The `cv2x_tcp_test` is a sample application available in [open-source](#). This tool demonstrates methods to establish a data connection from OBU to a SCMS server through a RSU using link-local IP connection, in a simplified manner. The tool can be configured as either client or server.

- On the OBU, the `cv2x_tcp_test` tool is configured to run as a TCP client. The user needs to manually configure the peer side's local-link address. As described in Chapter 1, the peer side's local link address must be broadcasted via WSA/WRA in a real application scenario. After successful establishment of the TCP connection, the client side starts Tx packet and waits for an echo from the server.
- On the RSU, the `cv2x_tcp_test` tool is configured to run as a TCP server but with proxy mode. It receives packets from OBU and forwards them to the SCMS server that is connected via ethernet in the following example.
- On the SCMS server, the `cv2x_tcp_test` tool runs as a simple TCP server that receives the forwarded packets from RSU and echoes them back.

The following figure explains the reference test configuration where OBU and RSU communicates over PC5 using link local address and SCMS server, and RSU communicates over ethernet using IPv4 or IPv6:

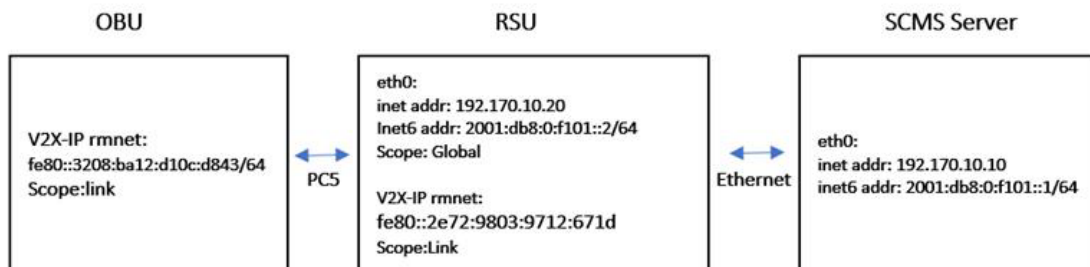

Figure 2-1 Reference test configuration

2.1 Command list and options of cv2x_tcp_test tool

The following table lists the command list and options of `cv2x_tcp_test` tool:

Table 2-1 Reference application: Command list and options

Option	Description
<code>-m <tcpMode></code>	<ul style="list-style-type: none"> ▪ 0-TCP_CLIENT ▪ 1-TCP_SERVER ▪ 2-TEST_MODE ▪ 3-SCMS_SERVER
<code>-d <dstAddr></code>	Destination IPv6 addresses used for connecting.
<code>-s <srcPort></code>	Source port used for binding. By default, it is 5000.
<code>-t <dstPort></code>	Destination port used for connecting. By default, it is 5000.
<code>-p <service ID></code>	Service ID used for Tx and Rx flows. By default, it is 1.
<code>-l <packet length></code>	Tx packet length. By default, it is 128.
<code>-n <packet number></code>	Tx packet number.
<code>-g <global IP prefix></code>	Set global IP prefix. By default, it is 2600:8802:1507:c700.
<code>-x <proxy_addr></code>	Proxy address for TCP_SERVER or local address for SCMS_SERVER.
<code>-X <proxy_port></code>	Proxy port. By default, it is 9000.
<code>-y <remote_addr></code>	Proxy remote address for TCP_SERVER.
<code>-Y <remote_port></code>	Proxy remote port. By default, it is 9000.
<code>-F</code>	Use IPv4 address for proxy. By default, it is IPv6.
<code>-H</code>	Help

Table 2-2 Command examples

Example	Description
<code>cv2x_tcp_test -h</code>	Sample application command line used for help.
<code>cv2x_tcp_test -m 0 -d <server addr></code>	Example command for client.
<code>cv2x_tcp_test -m 1 -x <proxy addr> -y <remote addr></code>	Example command for server proxy.
<code>cv2x_tcp_test -m 3 -x <proxy addr></code>	Example command for SCMS server.

NOTE:

- Only IPv6 is used over-the-air. The WWAN link between RSU and application server can be either IPv4 or IPv6.
- To reduce the complexity of `cv2x_tcp_test` reference tool, only one OBU at a time is supported on the RSU side.

2.2 Connection management due to link-local address change

Per IEEE 1609.3, IPv6 addresses are derived from random 3-byte L2 SRC addresses. Due to this, for TCP it is important to suppress unnecessary L2 changes that might originate in the radio, unrelated to pseudonym changes. It is suggested to disable any periodic L2 SRC address changes during OBU/RSU TCP sessions. This applies to both OBUs and RSUs which support global IPv6 addressing or link-local addressing.

The periodic V2X source L2 address update breaks the TCP connection between the OBU and RSU via PC5 using the 3GPP `TimerT5000` parameter value (in number of seconds). After T5000 timeout, an OBU or RSU picks a new random L2 SRC address.

For testing purposes, to extend the L2 address update interval for a longer duration, the parameter `TimerT5000` can be set to maximum of 65535 seconds.

In `v2x.xml`, modify the `<TimerT5000>` parameter value to the intended timer value.

```
<PrivacyConfig>  
  <TimerT5000>65535</TimerT5000>  
</PrivacyConfig>
```

On Qualcomm implementations, APIs and command tools are available to update this 3GPP 'Manage Object' XML configuration. For example, the C-V2X configuration command to reload the updated `v2x.xml` file is:

```
#cv2x-config --update-config-file <file_path/v2x.xml>
```

Whenever either OBU or RSU link-local address changes, the TCP connection can no longer be used. The tool will close the TCP connection and abort. If the user still has data to transmit, then the user must reconnect the system to complete the data transfer. In real application scenarios, the WAVE stack determines that the data transfer from OBU has not finished and try reconnecting to complete the data transfer.

2.3 Add link-local accommodations to ITS products for Internet application

IPv6 sessions between OBU and RSU are ideally established via the generic WSA/WRA advertised PSID, associated with IPv6 Internet access. The WRA includes a global IPv6 address prefix, DNS server and so on. However, for link-local device accommodation, the RSU WAVE stack has to advertise the RSU's C-V2X IPv6 link-local address for the OBU to connect to.

On the RSU, one or more proxies are preconfigured and run. The WSA are advertised via a published PSID that is specific to the server. The RSU that runs IEEE 1609.2 signs this WSA and broadcasts it periodically.

The OBU discovers the RSU via the IP application server's specific PSIDs. The OBU uses this information and other WSA information such as the RSU's location to decide when IP traffic is possible. The OBU application combines IP availability knowledge with application needs—for example, a misbehavior report to upload, or a certificate bundle to download—to determine when to start a TCP session. When the required conditions exist, the OBU initiates a TCP session with the IPv6 address and port number advertised in the WSA.

2.4 Implement OBU and RSU product ITS stacks

This section provides the steps to implement the ITS application on the OBU and RSU.

2.4.1 ITS application implementation on onboard unit

The following table lists the steps required to implement IP connection on an OBU using global IPv6 or link-local, and compares their implementation.

Table 2-3 Implement IP connection on an OBU using global IPv6 or link-local

Steps	Using IEEE 1609.3 global IPv6	Using link-local
1	Set TimerT5000 to 65535.	Same as global IPv6.
2	Set up a receiving subscription for any non-IP IEEE 1609.3 WSA+WRA broadcasts with an expected PSID for your application's TCP connection.	In link-local, PSID is dedicated to a known SCMS server or an application server instead of a generic Internet access.
3	Use IEEE 1609.2 security services (Aerolink) to verify whether the signature of the WSA is authentic and properly signed by a trusted certificate chain.	Same as global IPv6.
4	Select the appropriate RSU based on WSA parameters such as distance and signal quality.	Same as global IPv6.
5	Set up a transmit one-shot flow with the traffic class and priority specified in SAE J3161/0 deployment profiles. For Qualcomm Telematics SDK solutions, this means linking to a specific source port #. In Qualcomm global IPv6 system software, this has a special catch-all source port #0, which will be used for all TCP transmissions.	In link-local, similar to non-IP messages, the flow is associated between a single source port#. Hence, for each expected TCP client session, an event (ad-hoc/on-shot) transmit flow must be created with the source port that will be used by the TCP client.
6	As the application/security services determine the need for an Internet connection, perform the following steps:	Same as global IPv6.
a.	If WSA includes the limitations on distance, speed, and congestion at which the specific application must be attempted, wait for those conditions to be met.	Same as global IPv6.
b.	Suspend any periodic Basic Safety Message (BSM) pseudonym randomization during session.	Same as global IPv6.
c.	Set up the IPv6 networking for use with a specific RSU based on the following WRA parameters: - IPv6 global address prefix via TelSDK - DNS servers that may be used - Optionally, the RSU IP as the default Gateway/router.	NA
d.	Initiate TCP connection to the server. Ensure the traffic-class is set according to SAE J3161/0 for all packets to ensure selection of Per-packet Pro-se Priority (PPPP) 8.	In link-local, initiate TCP connection to the server where PSID advertised a proxy running on the RSU, the server IP will be the link-local address of the RSU.
e.	Set up Transport Layer Secure (TLS) session between OBU and SCMS server.	Same as global IPv6.
f.	Exchange TCP data (upload/download).	Same as global IPv6.
g.	Close the socket, resuming pseudonym change logic.	Same as global IPv6.

2.4.2 ITS application implementation on roadside unit

The following table lists the steps required to implement IP connection on a RSU using global IPv6 or link-local, and compares their implementation.

Table 2-4 Implement IP connection on a RSU using global IPv6 or link-local

Steps	Using IEEE 1609.3 Global IPv6 Steps	Using link-local
1	Set TimerT5000 to a large timeout to prevent extraneous L2 randomizations.	Same as global IPv6.
2	Ensure that the firewalls are enabled to allow RSUs to accept the expected incoming ports/source addresses on the C-V2X interface, and to allow the RSU to reach the expected Internet application servers.	Same as global IPv6.
3	Use the Qualcomm Telematics SDK library to set the global IPv6 prefix to be used for the RSU's C-V2X links.	NA
4	Preconfigure C-V2X one-shot/ad-hoc event transmit flow for the RSU to OBU downlink as per SAE J3161 parameters, using the special port #0 (Qualcomm implementation specific) to capture all IPv6 C-V2X transmissions. As a standard, Per-Packet Pro-se Priority (PPPP) must be set to 8.	In link-local, instead of the catch-all flow for all IP, create one for each expected SRC port matching the response port from the application server. One must be created for each application response port. For example, one on source port 443 for https.
5	Ensure that the IPv6 route from C-V2X radio to Internet is configured in the operating system.	Start a proxy <code>cv2x_tcp_test</code> (see Chapter 2) that listens on C-V2X interface on a specified port#. Depending on the service and backhaul, make this specific to either IPv4 or IPv6 for the required application server. For example, SCMS Registration Authority Server, probe data destination server, weather server and so on.
	a. NA	RSU proxy waits on a specific incoming port for connections from passing OBUs.
	b. Packet between OBU and Internet server is routed at 'layer 3' IP routing back and forth.	As OBU clients connect, the proxy makes a corresponding TCP connection to the Internet/LAN connected application server, using a unique local SRC port.
	c. NA	On proxy, relay payloads from air to wire connection and vice versa.
	d. NA	On C-V2X inactivity, end the proxy instance, and corresponding application server connection.

Steps	Using IEEE 1609.3 Global IPv6 Steps	Using link-local
6	The WRA/WSA includes global IPv6 address prefix. In the WSA, include the Location2D and parameters about when IP traffic is allowed.	In link-local, build or update the RSU's WSA with its WRA containing the C-V2X interface's IP address, and port number for each PSID or Internet server supported by the proxy system. The advertised address/port is link-local and a port of the RSU's listening proxy.
7	Use Aerolink and required certificates on a certified HSM to sign the WSA.	Same as global IPv6.
8	Broadcast WSA periodically.	Same as global IPv6.
9	Monitor L2 SRC address for any changes, which will trigger rebuilding of WRA.	Same as global IPv6.

3 Reference test configuration

This chapter describes a reference test configuration. In this reference test configuration, two devices are used to set up the test environment, where a single device is configured as both OBU and SCMS server proxy.

NOTE: In a real-world scenario, SCMS server is a separate entity as shown in [Figure 3-1](#).

For example, Device#1 (APQ8096+MDM9150) simulates the RSU and Device2 (SA2150P+SA515M) simulates the SCMS server and OBU. SA2150P and APQ8096AU are Qualcomm application processors. The user can use other non-Qualcomm application processors in their setup.

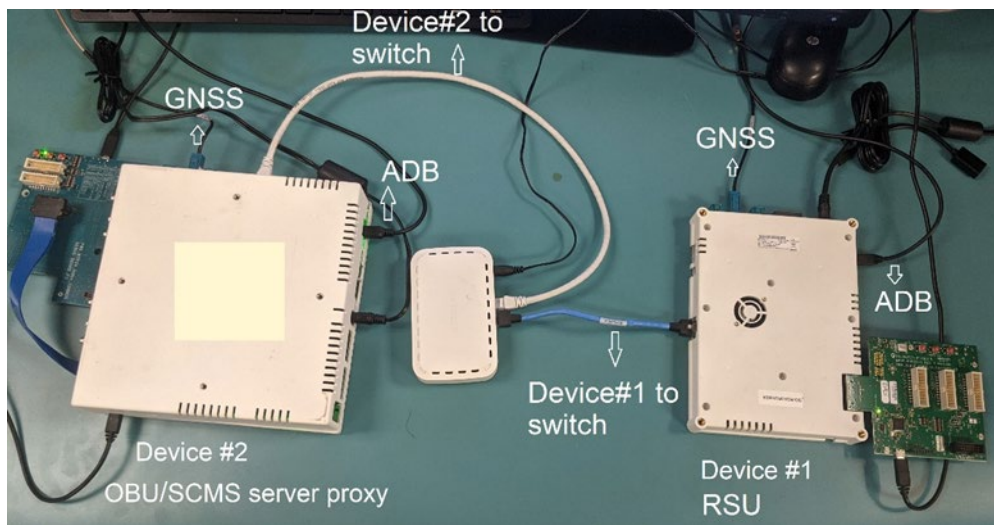

Figure 3-1 OBU and RSU connection to SCMS server

3.1 Run link-local adaptation of OBU/RSU cv2x_tcp_test

This section outlines the steps to transfer data from the OBU to SCMS server to the RSU using Qualcomm reference platforms. It is recommended that the application developer adapts to suit the device under test.

Prerequisites

- Device#1 as RSU (PC5, proxy)
 - Device#2 as OBU (PC5) and SCMS (Ethernet)
1. Ensure that the `TimerT5000` parameter randomizing is configured as described in Section 2.4.
 2. Connect Device#1 and Device#2 via Ethernet as shown in Figure 3-1.

- a. Use the following command to configure IPv4 address for eth0:

```
~ # ifconfig eth0 <IPv4 address>
```

For example, the user can assign 192.170.10.10 for the SCMS server eth0 on Device#2 and 192.170.10.20 for RSU eth0 on Device#1.

- b. To configure IPv6 address for eth0:

NOTE: Step (i) and (ii) are not required for Device#1.

- i. Add the following line to `/etc/sysctl.d/sysctl.conf`:

```
net.IPv6.conf.eth0.disable_IPv6 = 0
```

- ii. Issue the following command to enable the configuration:

```
# sysctl -p /etc/sysctl.d/sysctl.conf
```

- iii. Add the IPv6 address:

```
# ifconfig eth0 add <IPv6 address>
```

For example, the user can assign 2001:0db8:0:f101::1/64 for the SCMS server eth0 node on Device#2 and 2001:0db8:0:f101::2/64 for the RSU eth0 node on Device#1.

- c. The user can also run a ping test between Device#1 and Device#2 to verify that the two devices are communicating over Ethernet.

3. Verify that both Device#1 and Device#2 have GNSS feed and are able to generate position fixes.

```
~ Kinematics-sample-client -n 1
```

4. Start C-V2X on Device#1 and Device#2 using the command `systemctl`.

Ensure that the C-V2X Tx and Rx are active. To verify if both devices are using the same radio configurations, the user can run ITS stack on both devices and verify if the packets sent on one device are received on other device using ITS stack.

```
~ systemctl start cv2x
```

5. Start the SCMS server mode on Device#2 and specify its eth0 IPv6/IPv4 address to listen for the connection request from Device#1, that is, the RSU. The SCMS server accepts the RSU's connection request and echoes each received packet.

- To test the IPv6 proxy, use:

```
~ # cv2x_tcp_test -m 3 -x 2001:db8:0:f101::1
```

4 Feature support and availability

The following table captures the availability of IP addressing mechanisms in Qualcomm products for C-V2X. Qualcomm recommends that vendors use global IPv6 feature and to upgrade software, if possible. This table provides the schedule for feature availability. However, where modem software upgrade is not possible, link local IPv6 mechanism provides similar functionality as described in Chapter 1.

Table 4-1 Global IPv6 and link-local IPv6 support

Chip product	Global IPv6	Link-local IPv6
MDM9150	May 2022	Yes
SA515M	Yes	Yes

A References

A.1 Reference documents and websites

Table A-1 Reference documents and websites

No.	External websites
1.	Codelinaro / le / platform / vendor / QCOM-opensource / snaptel-SDK. Accessed March 16, 2022. https://git.codelinaro.org/clo/le/platform/vendor/qcom-opensource/snaptel-sdk/-/blob/telsdk.lnx.1.0/apps/tests/cv2x_tcp_test/Cv2xTcpTest.cpp

A.2 Acronyms and terms

Table A-2 Acronyms and terms

Acronym or term	Definition
OBU	On board unit
C-V2X	Cellular Vehicle-to-Everything
SCMS	Security Credential Management System
RSU	Roadside unit
WSA	WAVE Service Advertisement
WRA	WAVE Routing Advertisement
TCP	Transmission Control Protocol
V2I	Vehicle to Infrastructure
WWAN	Wireless Wide Area Network
IPv6	IP version 6
DNS	Domain Name System
ITS	Intelligent Transportation Systems
PSID	Provider's service ID